



better together

# Data sheet

## DRG 1000/2/80 B0FT5

**GREY**  
series

### Technical specification

**3~ 50 Hz**

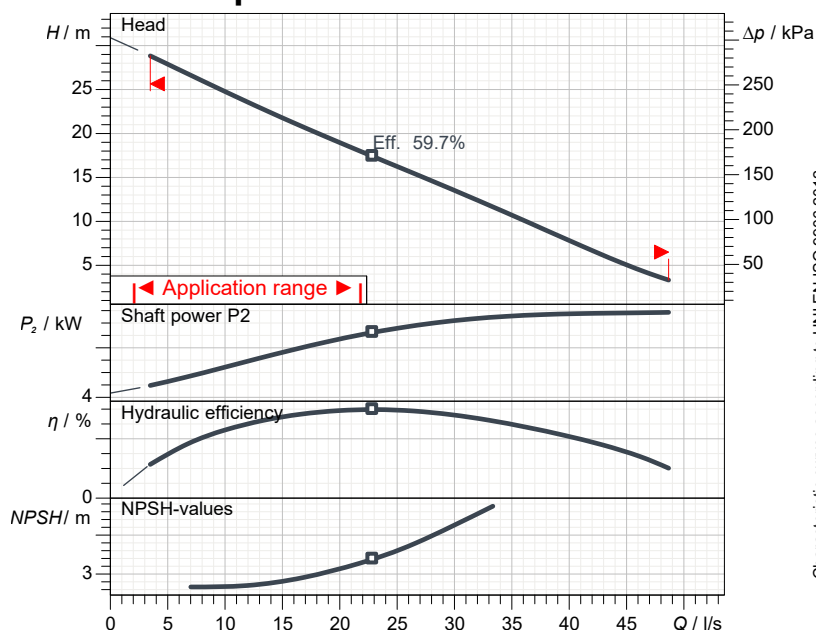

Characteristic curves according to UNI EN ISO 9906:2012

P<sub>2</sub><10kW: paragraph 4.4.2

10kW<P<sub>2</sub><100kW: Grade 3B

P<sub>2</sub>>100kW: Grade 2B

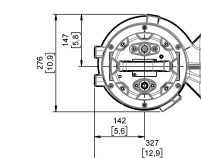
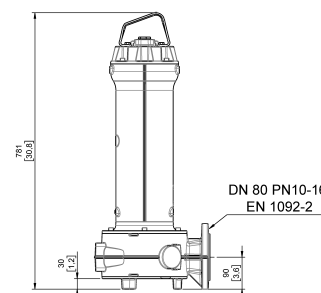

[ mm  
[inch]]

#### Pump

Series	GREY series
Type	DRG 1000/2/80 B0FT5
Version	TS 10 400D NN NN GG

#### Operating limits (standard pumps)

Max. ambient temperature	40 °C
Max. density treated liquid	1100 kg/m <sup>3</sup>
pH treated liquid	6 ÷ 14
Max. start per hour (equally distributed)	20
Wet/dry use	WET
Max. acoustic pressure level	70 dB
Operating mode*	Continuous use - S1
	Discontinuous use (excluding FM models) S3 = 10%

\*check the minimum operating level on dimensional drawing page

#### Motor data

Rated voltage	400 V
Frequency	50 Hz
Motor phases	3~
Number of poles	2
Rated power P <sub>2</sub>	7.50 kW
Incoming power P <sub>1</sub>	8.51 kW
Rated current	13.7 A
rpm	2873 1/min
Efficiency	88.1 %
cos φ	0.894
Rated torque	24.9 Nm
Start	Direct starting
Starting current	92.1 A
Starting torque	79.8 Nm
Degree of protection	IP 68
Insulation class	H
Capacitor	
Starting Capacitor	

#### Construction materials

Case	Cast iron EN-GJL 250
Shaft	Stainless steel AISI 431
Hydraulic	Cast iron EN-GJL 250
Impeller	Cast iron EN-GJL 250
Painting/Coating	Bi-epoxy 200 μm sea water
Screws	Stainless steel - Class A2-70
Gaskets	NBR

#### Construction features

Cooling system	No cooling jacket
Main cable	4G1,5 + 3x1
Cable length	10 mt
Mechanical seals	2 in silicon carbide (2SiC)
Additional drilling	-
Weight*	79.2 kg
Electrical variant	Thermal protection and leakage sensor

\* cable and fixing system excluded

#### Hydraulic

Free passage	55 x 50 mm
Impeller type	Open channel impeller
Max. hydraulic efficiency	59.7 %
Suction	DN 80 UNDRILLED
Discharge	DN 80 EN 1092-2

Rev.4 - 09/03/2022

All data shown are not binding. Zenit reserves the right to change data and dimensions without notice.

Created on 2024-03-08

zenit.com

Page 1 / 3



better together

# Data sheet DRG 1000/2/80 B0FT5

GREY  
series

## Pump performance curves

3~ 50 Hz

<b>Impeller type</b> Open channel impeller		<b>Free passage</b> 55 x 50 mm	<b>Discharge</b> DN 80	<b>Suction</b> DN 80	
<b>DUTY POINT</b>					
<b>Flow</b>	<b>Head</b>	<b>Shaft power P2</b>	<b>Hydraulic efficiency</b>	<b>Density</b> 998.3 kg/m <sup>3</sup>	<b>Viscosity</b> 1.005 mm <sup>2</sup> /s

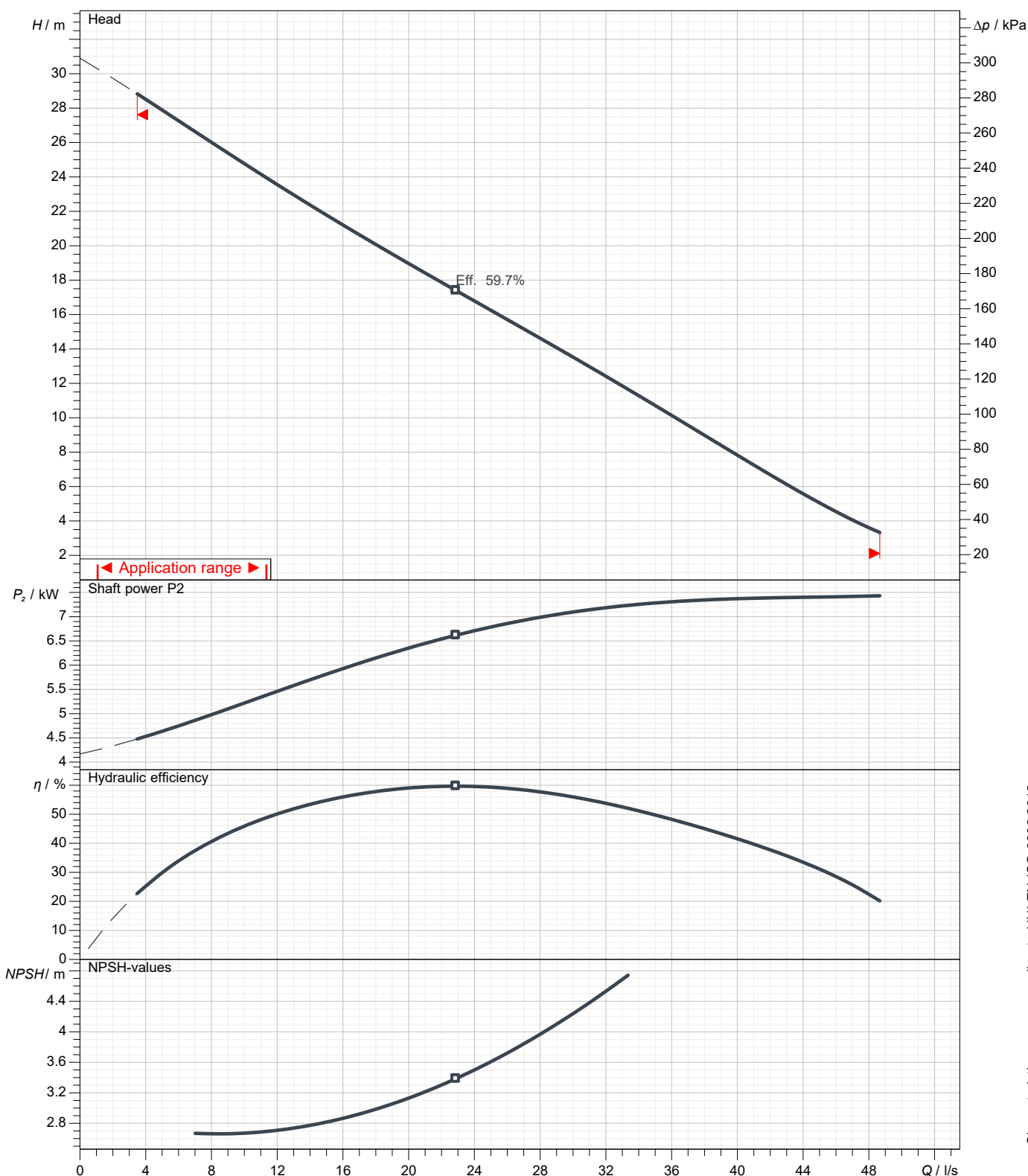

Characteristic curves according to UNI EN ISO 9906:2012  
P2<10kW: paragraph 4.4.2  
10kW<P2<100kW: Grade 3B  
P2>100kW: Grade 2B



better together

# Data sheet DRG 1000/2/80 B0FT5

GREY  
series

## Dimensional drawing

3~ 50 Hz

<b>Installation type</b> Installation with bottom coupling device - Vertical outlet		
<b>Wet/dry use</b> WET	<b>Drilling variant</b>	<b>Flushing valve - drilling</b> -
<b>Discharge</b> DN 80 EN 1092-2	<b>Suction</b> DN 80 UNDRILLED	<b>Pressure rating (suction/discharge):</b> -/PN 10
<b>Accessory</b> DAC 80/80V+KAF 116-2" EN (P)		<b>Accessory code</b> 9001.032
<b>Note: Accessory must be ordered separately</b>		

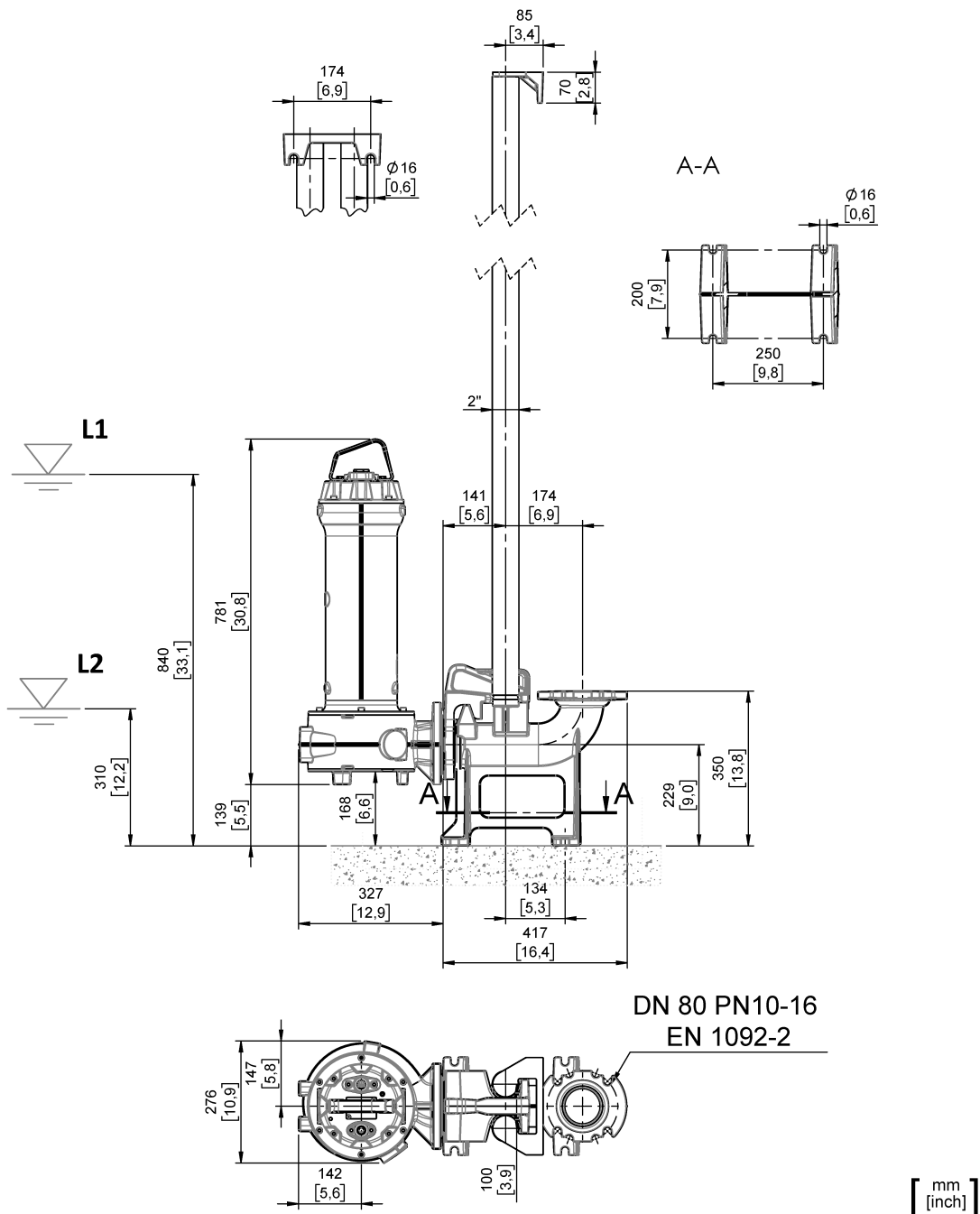

L1: Minimum operating level for S1 - continuous use

L2: Minimum operating level for S3 - discontinuous use (excluding FM models)